

## PSD SPC module

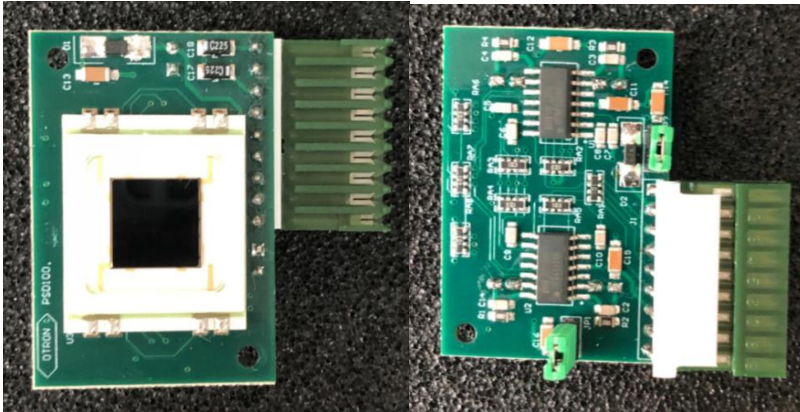

The PSD100-SPB2 is a 10mm X 10mm dual axis position Sensing diode on a PCB with sum and difference amplifiers. It also contains circuitry for applying a 14.3V bias voltage To the position sensing diode. Or the user can externally Apply a bias voltage.

Outputs are bipolar voltage analogs of the X and Y position Of the light spot centroid, as well as the total X current and The total Y current. The sum outputs may be used to externally Normalize the X and Y difference outputs. By normalizing the X And Y signals, they become independent of fluctuations in light Spot intensity.

## Application

- ◆ Position Measuring
- ◆ Guidance Systems
- ◆ Solar Tracking Systems

## Absolute Maximum Rating

Symbol	Parameter	Min.	Max.	Typ.	Units
T <sub>STD</sub>	Storage Temp.	-15	+100	25	°C
T <sub>OP</sub>	Operating Temp	0	+70	25	°C
V <sub>S</sub>	Power Supply Voltage	±10	±18	±12	V
V <sub>R</sub>	Applied Bias Voltage	0	10	5	V

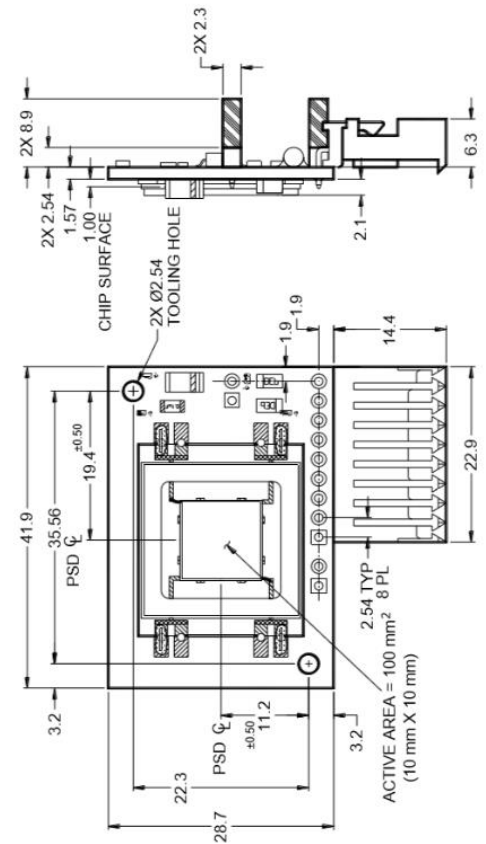

Information in this technical datasheet is believed to be correct and reliable. However, no responsibility is assumed for possible inaccuracies or omission. Specifications are subject change without notice.

OTRON ELECTRONIC TECHNOLOGY CO., LTD

TEL:+86-21-54971821

FAX:+86-21-54971823

EMAIL: [otron.sensor@gmail.com](mailto:otron.sensor@gmail.com)

<http://www.e-otron.com>

## Pin legs

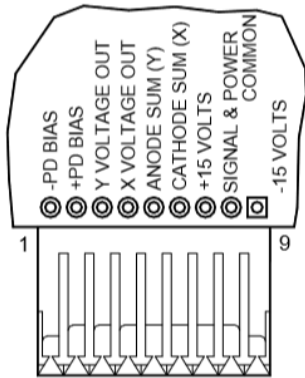

## Spectral response

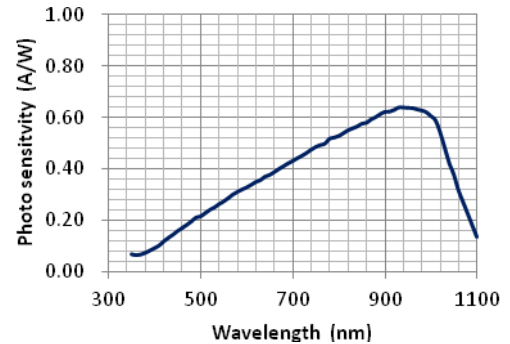

## Optoelectronic Characteristics @25°C

Symbol	Parameter	Test Conditions	Min.	Typ.	Max	Units
$V_O$	All Output Voltage	$V_S=\pm 15V, V_R=0V$	$-V_S+3$	-	$+V_S-3$	V
$I_O$	Output current	$V_S=\pm 15V, V_R=0V$	-	-	25-	mA
	Slew rate	$V_S=\pm 15V, V_R=0V$	-	10	-	V/us
	Theoretical noise	$V_S=\pm 15V, V_R=0V$	-	15	-	nV/Hz
$f_{3dB}$	3dB bandwidth**	$V_S=\pm 15V, V_R=0V, \lambda=880nm$	-	257	-	kHz
	Resolution**	$V_S=\pm 15V, V_R=0V, \lambda=880nm$	1.0			um
	Linearity**	$V_S=\pm 15V, V_R=0V, \lambda=880nm$		$\pm 1$		% of full scale
	Maximum light intensity	$V_S=\pm 15V, V_R=0V, \lambda=880nm$			1.5	W/cm <sup>2</sup>

\* Actual bias voltage to photodiode: pad 1 voltage times 0.95. \*\* Dependant on bias voltage.

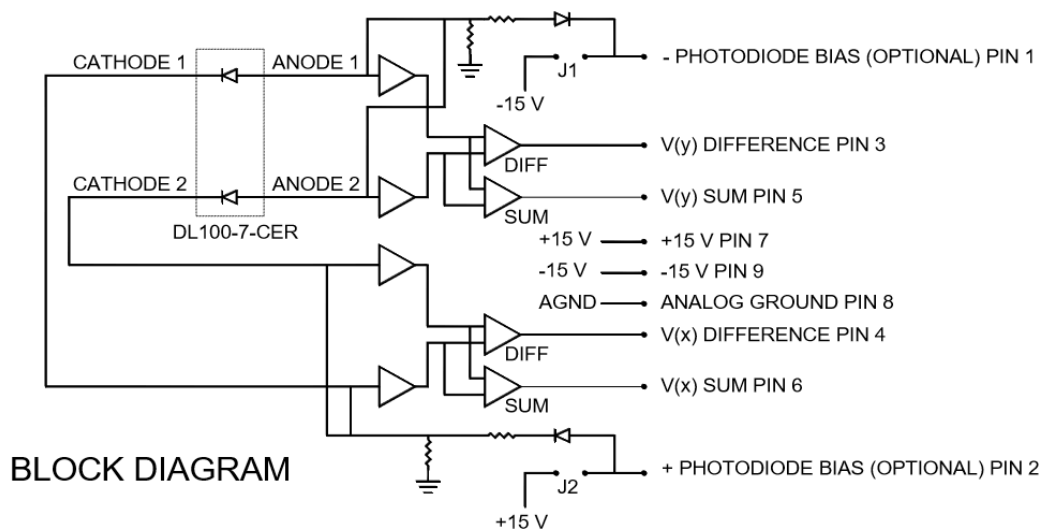



## APPLICATION NOTES

### Outputs

The PSD100-SPB2 module contains amplifiers that convert the light generated currents into voltages. The voltages are then processed to provide a bipolar signal for the X axis and a bipolar signal from the Y axis. The currents are further processed to provide a voltage for the total X current and the total Y current. These voltages represent the light intensity. Note: the X SUM output voltage is negative, the Y SUM is positive.

### PSD Biasing

Position sensing diodes of the type used in the PSD100-SPB2 module are more accurate if a reverse bias is applied across the diode. Installing jumpers J1 and J2 will engage circuitry that uses the supply voltage to create and apply a reverse bias of ~95% of the supply voltage (14.3 volts with a +/-15 V supply). In this configuration, there should be no connection to Pins 1 and 2. For bias voltages other than 14.3 volts, remove jumpers J1 and J2 and hook up an external bias source to Pins 1 and 2. (For zero bias operation, just remove jumpers. No connection is necessary to Pins 1 and 2). Although reduced bias will degrade the linearity performance of the PSD, voltage offset and noise can be improved. Determining the optimum bias voltage for each application is usually a "trial and error" procedure. If determining positions over a large area of the PSD is required, the built-in 14.3 volts bias is probably the best option. If low light levels and/or small incremental movement over a small area of the PSD are the application, then zero to low bias voltage may work best.

### Effects of Light Spot Shape, Size and Intensity

Since the photodiode current appears to be generated at the centroid of the light spot power density, it is the centroid location that is tracked by the voltage outputs. If any of the light spot is off the photodiode then the centroid of the light that does fall in the photodiode is the location tracked.

The ultimate resolution of the position sensor is signal to noise limited. Consequently, the spot intensity should be as great as possible without causing damage to the photodiode. There is a limit to the intensity. The spot size and intensity should not concentrate the beam such that the light power locally heats the detector surface above 110C. In practice the light intensity should never exceed 1.5 W/cm<sup>2</sup>. Many applications use an intensity of 1 to 3 milliwatts for a spot size of 1 mm<sup>2</sup>.

The current outputs of the photodiode are dependent on the light intensity and as a result the voltage outputs are also dependent on light intensity. If the beam source changes intensity when the spot location is being sensed, then the output should be normalized using the sum signals available on the PSD100-SPB2. Normalization is accomplished externally by dividing the location voltage by the sum voltage for the layer (X or Y) being measured. The PSD100-SPB2 does not normalize the location output signals.

### Ambient Light Considerations

Ambient light can cause errors and reduced resolution. If the ambient light is of homogenous power density over the entire diode surface it will appear as a current source at the diode center. Since this



# PSD100-SPB2

apparent source adds to the signal current the overall current is increased. The differencing circuits will eliminate this current from the X, Y outputs but it will still be included in the sum circuit outputs.

If the beam to be tracked is monochromatic, or nearly so, a bandpass filter can be placed in front of the diode to eliminate most of the ambient light. If the ambient light contains shadows that fall on the diode surface, the apparent current source will be off center and will contribute to an offset in the position outputs as well as contributing to the sum outputs. Again, an optical filter can eliminate or reduce most of these undesirable effects.

If the ambient light contains shadows that are changing with time then the position outputs and the sum circuit outputs will also show a time varying signal that is related to the shifting ambient light.

## Resolution

Best resolution is obtained with the maximum allowable light intensity and optimum wavelength. The temperature should be held within specification. Resolution obtainable under specified conditions is 0.5  $\mu\text{m}$  or less.

## Speed of Response

Increasing the PSD bias voltage will increase the speed of the PSD100-SPB2. The internally created reverse bias of 14.3 volts is sufficient for most applications. As noted above, Pins 1 and 2 are provided to reduce the 14.3 V reverse bias, but biasing above 14.3 volts provides only a small increase of speed. Care should be taken not to exceed the circuit common mode values and the breakdown voltage of the diode. See Absolute Maximum Ratings on page one.

The rise and fall time of the PSD100-SPB2 module with the 1  $\text{cm}^2$  PSD100-IC diode is better than 5  $\mu\text{s}$ .

## Linearity

Linearity improves with increased reverse bias. The 14.3 V bias provided by the PSD100-SPB2 module gives a linearity of  $\pm 1$  percent of full scale or better.

## Temperature Considerations

The operation temperature must be between 0 to 70C. For best resolution the temperature should be kept at or below 25C. Thermal gradients across the detector will cause position errors and should be avoided.

## Offsets

Precision components are used in the circuitry but as much as 250 millivolts of dark offset may still be present in the outputs. If this causes a problem the offsets should be removed externally.

Information in this technical datasheet is believed to be correct and reliable. However, no responsibility is assumed for possible inaccuracies or omission. Specifications are subject change without notice.

---

OTRON ELECTRONIC TECHNOLOGY CO., LTD

TEL:+86-21-54971821

FAX:+86-21-54971823

EMAIL: [otron.sensor@gmail.com](mailto:otron.sensor@gmail.com)

<http://www.e-otron.com>