

High speed Photodiode

OSX0184



Description

The OSX0184 is high speed, high sensitivity silicon Photodiode with high bandwidth.

OSX0184 are available with a flat window or ball lens.

Features

- * High speed response
- * Low dark current
- * High reliability in demanding environments
- * Operating temperature is from -40 to +80°C
- * Storage temperature is from -40 to +100°C

Applications

- * High speed photometry
- * High speed switch
- * pulse light detection
- * High speed optical communications
- * Fiber optic light monitoring

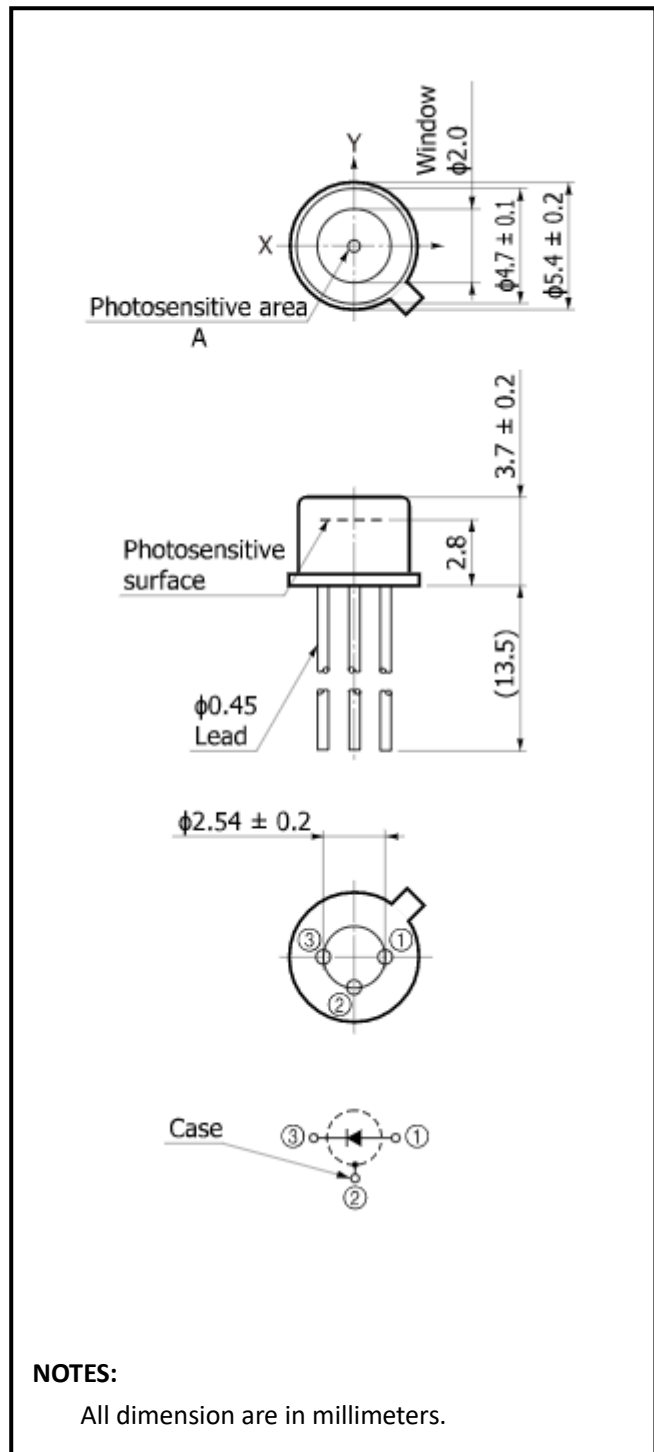

Information in this technical datasheet is believed to be correct and reliable. However, no responsibility is assumed for possible inaccuracies or omission. Specifications are subject change without notice

Absolute Maximum Ratings (Ta=25°C)

Parameter	Symbol	Condition	Min.	Typ.	Max.	Unit
Chip size	S			0.4*0.4		mm
Active area	A			Φ 0.184		mm
Dark current	I _D	V _R =0V		0.10		nA
Temp coefficient of I _D	T _{CID}			0.18		times/°C
Rise time	t _R	V _R =5V;λ=850nm;R _L =50Ω		0.5		ns
Reverse breakdown voltage	V _{(BR)R}	I _R =100μA Ev=0lx	20			V
Junction Capacitance	C _J	V _R =1V f=1MHz		1.237		pF
Photo sensitivity	S _R	830nm		0.54		A/W
Spectral Application Range	λ _{range}		400		1100	nm
Spectral Response-Peak	λ _p			830		
Shunt resistance	R _{sh}	V _R =10mV		0.10		GΩ
Rsh Temperature Coefficient	TC R _{sh}	Ev=100lx , V _R =10mV		0.18		%/°C
Angular Resp 50% Resp Pt	θ _{1/2}			±35		Degrees
Noise Equivalent Power	NEP	V _R =10V λ=830nm		1.8×10 ⁻¹⁴		W/Hz ^{1/2}
Specific Detectivity	D*	V _R =10V λ=830nm		3.9×10 ¹³		cm(Hz/W) ^{1/2}

Application Circuit:

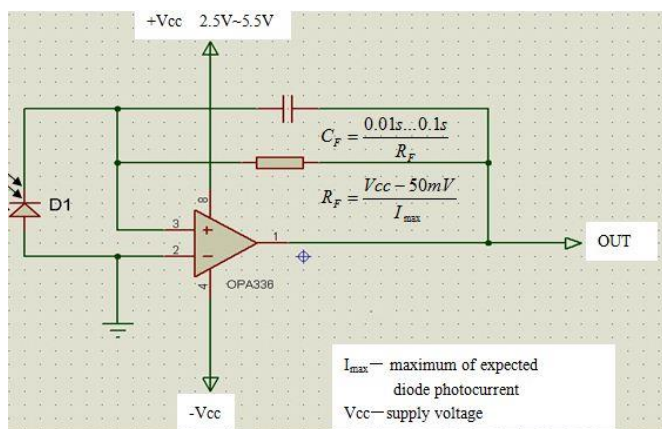

Information in this technical datasheet is believed to be correct and reliable. However, no responsibility is assumed for possible inaccuracies or omission. Specifications are subject change without notice

■ Dark current vs. reverse voltage

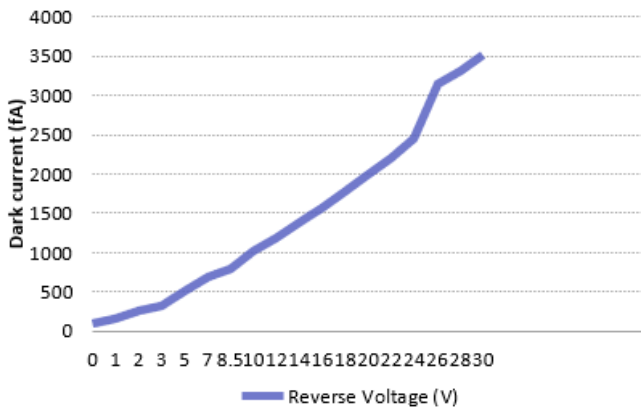

■ Spectral response

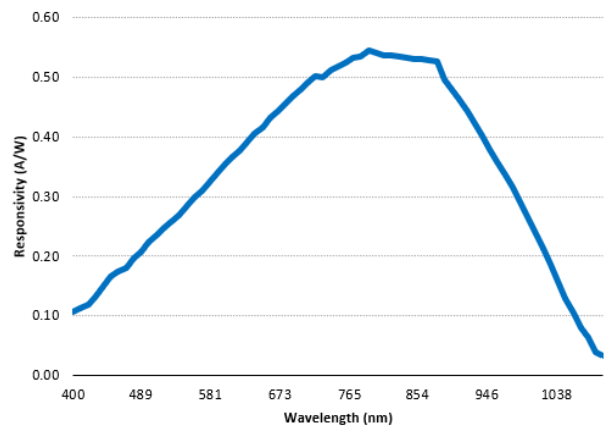

■ Capacitor vs. reverse voltage

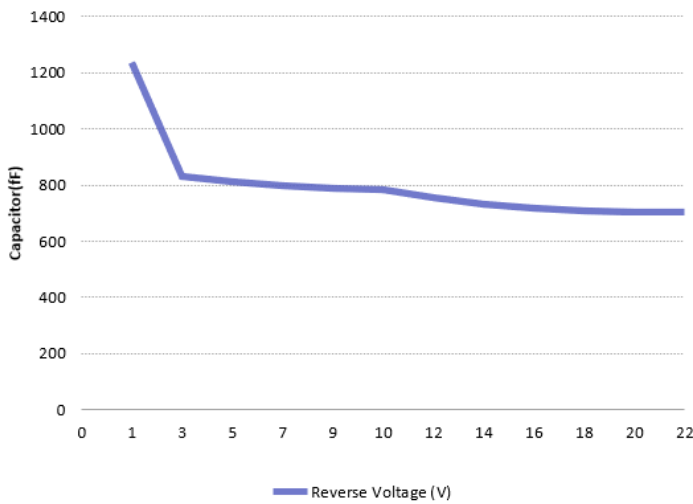

Information in this technical datasheet is believed to be correct and reliable. However, no responsibility is assumed for possible inaccuracies or omission. Specifications are subject change without notice