

Color Light-to-Digital Converter

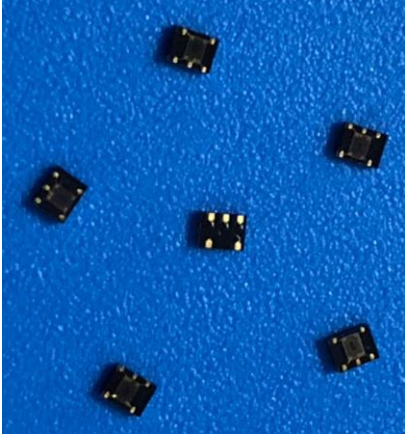

1. Description

The ALS34725 device will perform color temperature measurement, brightness sensing. An internal state machine provides the ability to put the device into a low power state between color temperature measurement providing very low average power consumption.

2. Features

*Color Temperature and Ambient Light Sensing

Low Power Management

- I2C Fast Mode Interface Compatible
- 16 Bit resolution
- IR blocking filters
- Programmable Gain & Integration Time
- Power Management
 - Low Power 1uA Sleep State
- I2C Interface Compatible
 - Up to 400kHz (I2C Fast Mode)
 - Device addr. : 7'b1000_011 (R/W, ADDR float)
7'b1000_010 (R/W, ADDR low)

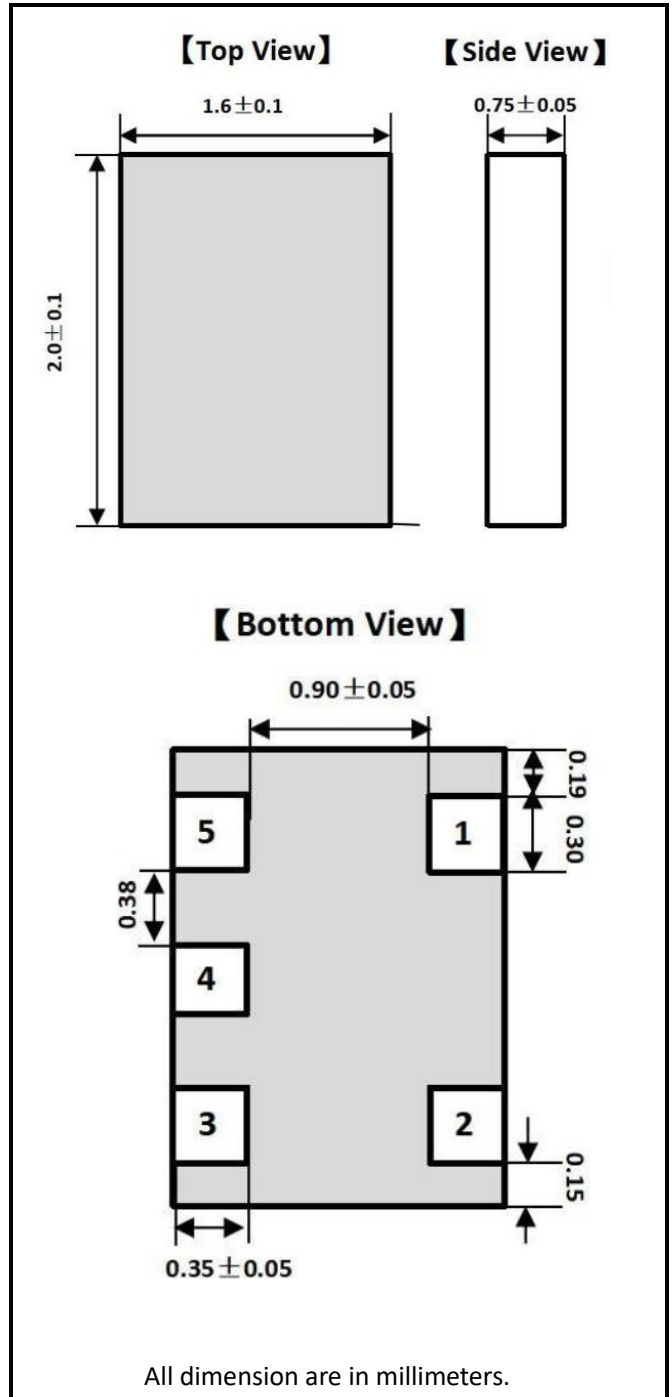

3.Applications

- *Brightness Sensing
- *Color Temperature Sensing
- *Notebook
- *Handheld device
- *Industrial and medical application

3.1 Typical Application Circuit

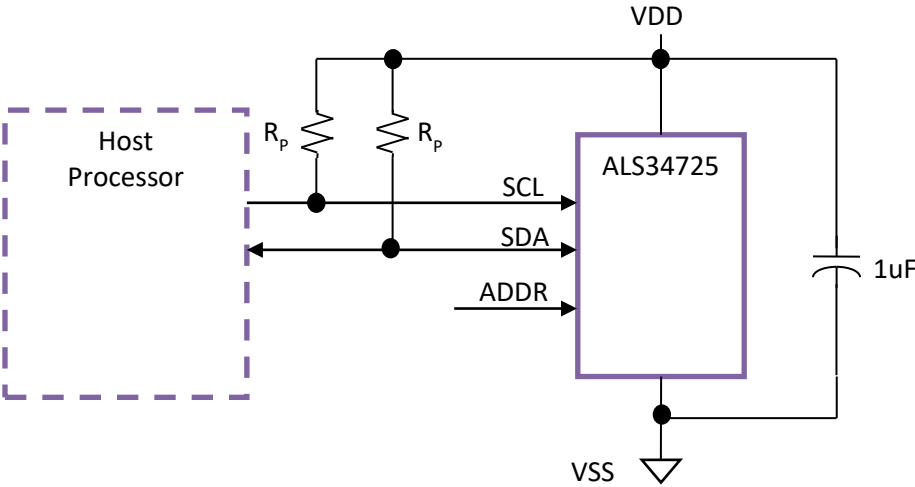

Pin Configuration and Functions

PIN	TYPE	DESCRIPTION
SCL	I	I2C serial clock input terminal
SDA	I/O	I2C serial data input/output terminal
VDD	P	Supply voltage
VSS	G	Supply Ground
ADDR	I	I2C device address input terminal (internal pull-up) - High or Floating : 7'b1000_011 - Low : 7'b1000_010

Information in this technical datasheet is believed to be correct and reliable. However, no responsibility is assumed for possible inaccuracies or omission. Specifications are subject change without notice.

4. Absolute Maximum Ratings

SYMBOL	PARAMETER	MIN	MAX	UNIT
VDD	Power Supply Voltage	-0.5	3.6	V
Vin	Input Voltage	-0.5	VDD	V
Vout	Output Voltage	-0.5	VDD	V
Tj	Junction Temperature	-40	85	°C

+ Stresses beyond those listed under “absolute maximum ratings” may cause permanent damage to the device. These are stress ratings only and functional operation of the device at these or any other conditions beyond those indicated under “recommended operating conditions” is not implied. Exposure to absolute-maximum-rated conditions for extended periods may affect device reliability.

Note 1: All voltage values are with respect to VSS.

5.1 ESD Ratings

SYMBOL	PARAMETER	VALUE	UNIT
VESD	Human-Body Model (HBM)	+/- 8000	V
	Machine Model (MM)	+/- 800	

5.2 Recommended Operating Conditions

SYMBOL	PARAMETER	MIN	TYP	MAX	UNIT
VDD	Power Supply Voltage	0.5	3.3	3.6	V
Vin	Input Voltage	0		VDD	V
Vout	Output Voltage	0		VDD	V
TA	Operating ambient temperature	-40		+85	°C

5.3 Electrical Characteristics (VDD = 3.3V, Ta = 25°C)

PARAMETER	TEST CONDITIONS	MIN	TYP	MAX	UNIT
Supply Current	Active		300	350	uA
	Sleep (@ADDR high)		1	10	
	Sleep (@ADDR low)		16	25	
SDA output low voltage	3mA sink current	0		0.4	V
	6mA sink current	0		0.6	
Low Level Input Voltage				VDD*0.3	V
High Level Input Voltage		VDD*0.7			V

Data Transmission Timing Requirements

PARAMETER	CONDITIONS	MIN	MAX	UNIT
Output Low Level (SDA)	IOL = 4mA		0.5	V
SCL Operating Frequency			400	kHz
Stop and Start Condition		1.3		us
Hold Time After Repeated Start Conditions		0.6		us
SCL Clock Low Period		1.3		us
SCL Clock High Period		0.6		us
Repeated Start Condition Setup Time		0.6		us
Data Hold Time		0	0.9	us
Data Setup Time		100		ns
Clock/Data Fall Time			300	ns
Clock/Data Rise Time			300	ns
Stop Condition Setup Time		0.6		us



5.4 Optical Characteristics (VDD = 3V, Ta = 25°C)

PARAMETER		TEST CONDITIONS	MIN	TYP	MAX	UNIT
Peak Sensitivity Wavelength of ADC	R			630		nm
	G			550		nm
	B			480		nm
	C			590		nm
	IR			870		nm
Counter Value of ADC	R	3000K WLED, 1400Lux, Integration Time 10ms, AGAIN=1		7007		counts
	G			8903		counts
	B			4476		counts
	C			18341		counts
	IR			2946		counts
Dark Count Value		Dark, Integration Time 100ms, AGAIN=1	0	1	3	counts
ADC count Range			0		65,535	counts
Gain scaling		AGAIN = 0 AGAIN = 1 AGAIN = 2 AGAIN = 3		1 1.5 2 2.5		x

5.5 Typical Performance Characteristics

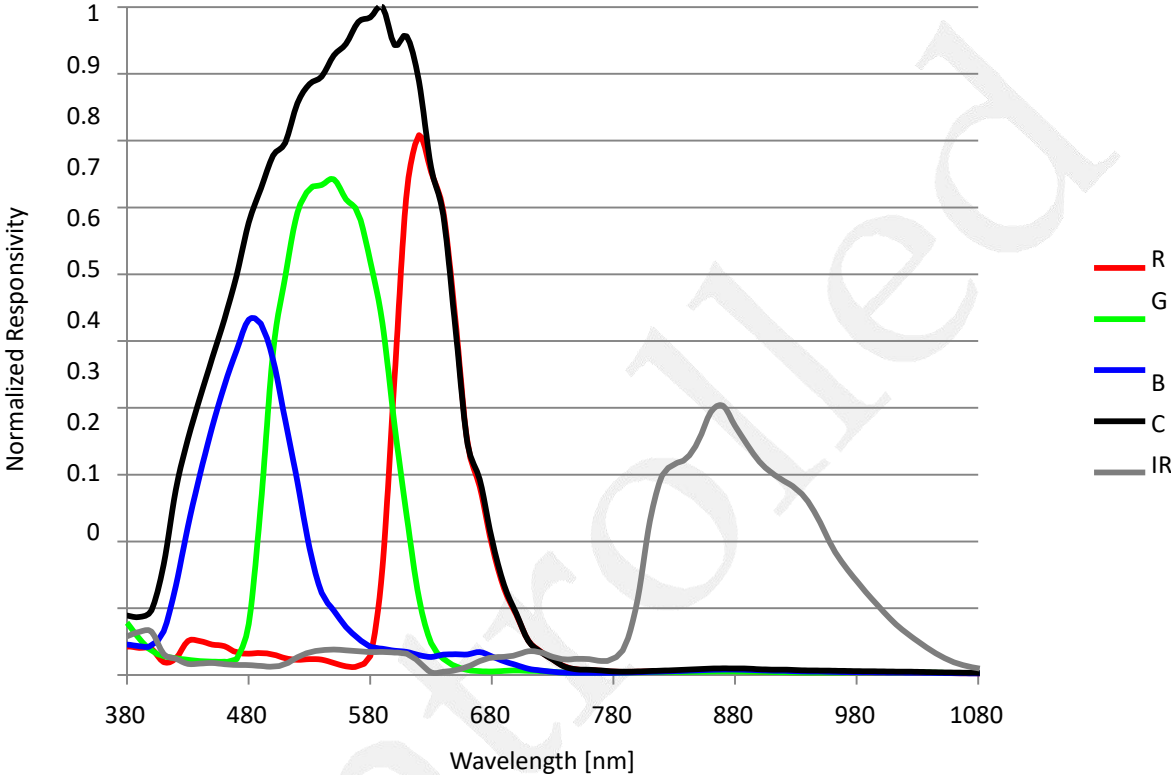

< Normalized Spectral Response >

Information in this technical datasheet is believed to be correct and reliable. However, no responsibility is assumed for possible inaccuracies or omission. Specifications are subject change without notice.

6. Detailed Description

6.1 Overview

The ALS34725 light-to-digital device provides on-chip RGBC and IR diodes, integrating amplifiers, ADCs, accumulators, clocks, buffers, comparators, a state machine and an I2C interface. Four integrating ADCs simultaneously convert the amplified photodiode currents into a digital value providing up to 16 bits of resolution.

The device connects to a video processor or image sensor through a standby I2C interface which supports up to 400-kbits/s data rate. The digital interface supports IO levels from 1.8V to 3.3V.

Function Block Diagram

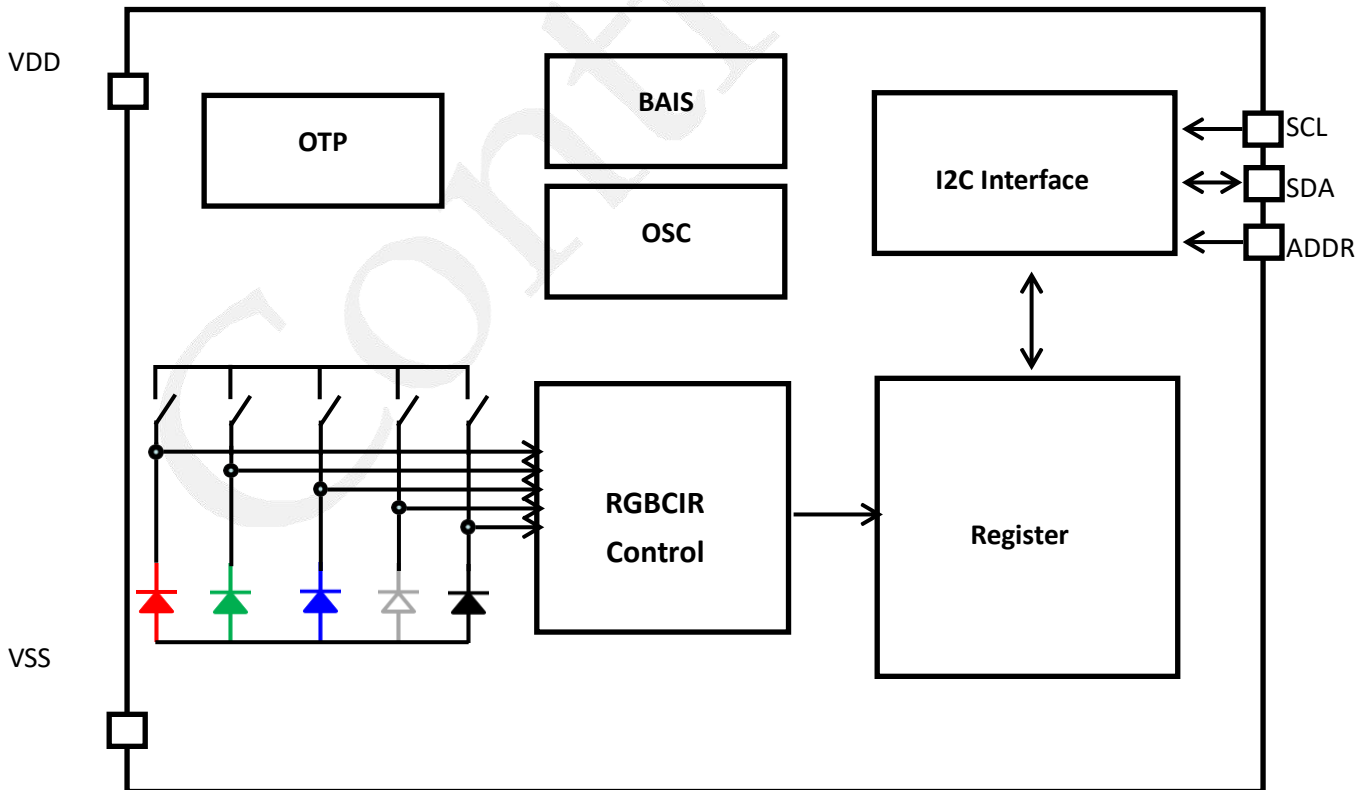

6.2 Feature Description

6.2.1 System State machine

The ALS34725 device provides ambient light and color temperature sensing. The internal state machine manages the operation of the device. It controls the RGB functionality and power down modes. Average power consumption is managed via control of variable endurance low power wait cycles.

The advanced digital color light sensor portion of the ALS34725 contains a segmented circular photodiode array used for color measurements.

This architecture provides stable color sensing independent of the incident angle of light. Five integrating analog-to-digital converters (ADCs) integrate light energy from photodiodes simultaneously.

Communication with the device is accomplished through a fast (up to 400 kHz) two wire I²C serial bus for easy connection to a microcontroller or embedded controller. The device typically draws only 300uA in color operation and 1uA during power down.

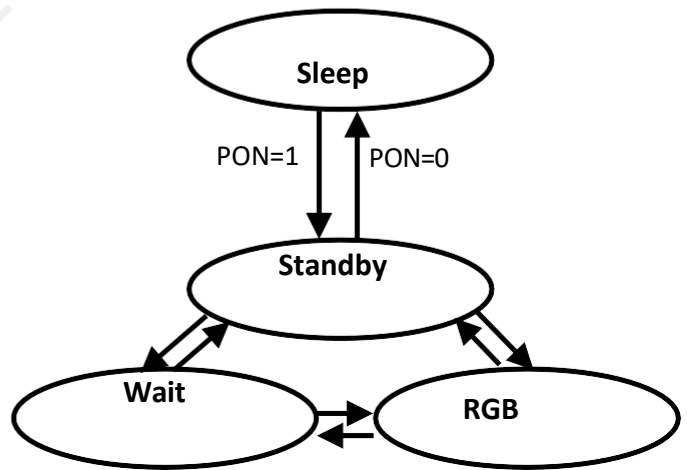

< State machine >

6.3 Programming

6.3.1 I²C Protocol

Interface and control of the ALS34725 is accomplished through an I²C serial compatible interface (standard or fast mode) to a set of registers that provide access to device control functions and output data. The device supports a selectable I²C address between b1000_011 and b1000_010 using 7-bit addressing protocol.

The I²C standard provides for three types of bus transaction: read, write, and a combined protocol. During a write operation, the first byte written is a command byte followed by data. In a combined protocol, the first byte written is the command byte followed by reading a series of bytes. If a read command is issued, the register address from the previous command will be used for data access.

- A Acknowledge (0)
- N Not Acknowledged (1)
- P Stop Condition
- R Read (1)
- S Start Condition
- Sr Repeated Start Condition
- W Write (0)
- ... Continuation of protocol
- Master-to-Slave
- Slave-to-Master

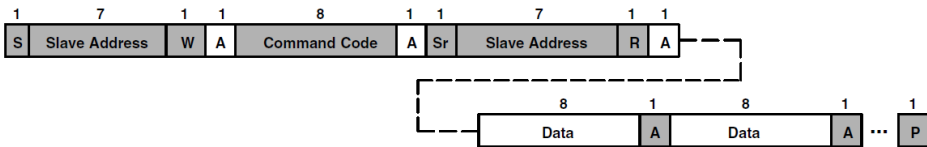
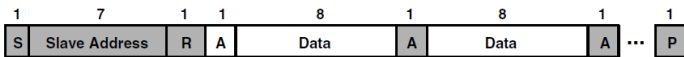
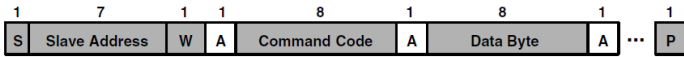

6.4 Register Maps

Addr	Bit7	Bit6	Bit5	Bit4	Bit3	Bit2	Bit1	Bit0	DEF
0x80	RESERVED			DARK_EN	RESERVED	W_EN	RGB_EN	PON	0x00
0x81	IRGAIN		RGB_GAIN		W_TIME	RGB_TIME			0x00
0x82	DEVICE ID								0x24
0x83	REVISION ID								0x00
0xA0	ADC_R[7:0]								0x00
0xA1	ADC_R[15:8]								0x00
0xA2	ADC_G[7:0]								0x00
0xA3	ADC_G[15:8]								0x00
0xA4	ADC_B[7:0]								0x00
0xA5	ADC_B[15:8]								0x00
0xA6	ADC_C[7:0]								0x00
0xA7	ADC_C[15:8]								0x00
0xA8	ADC_IR[7:0]								0x00
0xA9	ADC_IR[15:8]								0x00

6.4.1 Enable Register

Addr	Bit7	Bit6	Bit5	Bit4	Bit3	Bit2	Bit1	Bit0	DEF
0x80	RESERVED			DARK_EN	RESERVED	W_EN	RGB_EN	PON	0x00

FIELD	BITS	DESCRIPTION
DARK_EN	4	Dark Offset cancellation Enable.
W_EN	2	Wait State Enable.
RGB_EN	1	RGB, Clear and IR controller Enable.
PON	0	Power ON. This bit activates the internal analog circuit to permit the timers and ADC channels to operate. Writing a 1 activates analog circuit. Writing a 0 disables analog circuit. During reads and writes over the I ² C interface, this bit is temporarily overridden and analog circuit is enabled, independent of the state of PON.

6.4.2 Gain & Time control Register

Addr	Bit7	Bit6	Bit5	Bit4	Bit3	Bit2	Bit1	Bit0	DEF
0x81	IRGAIN		AGAIN		W_TIME	RGB_TIME			0x00

FIELD	BITS	DESCRIPTION
IRGAIN	[7:6]	IR Gain 0 : 1x, 1: 0.5x, 2: 0.25x, 3: 0.125x
AGAIN	[5:4]	Analog Gain 0 : 1x, 1: 1.5x, 2: 2x, 3: 2.5x
W_TIME	3	WAIT Time 0 : 10ms, 1: 100ms
RGB_TIME	[2:0]	Optical Integration Time 0: 10ms, 1: 20ms, 2: 40ms, 3: 80ms 4: 100ms, 5: 200ms, 6: 400ms, 7: 800ms

6.5.6 ADC Data

Addr	Bit7	Bit6	Bit5	Bit4	Bit3	Bit2	Bit1	Bit0	DEF
0x82	DEVICE ID								0x24
0x83	REVISION ID								0x00
0xA0	ADC_R[7:0]								0x00
0xA1	ADC_R[15:8]								0x00
0xA2	ADC_G[7:0]								0x00
0xA3	ADC_G[15:8]								0x00
0xA4	ADC_B[7:0]								0x00
0xA5	ADC_B[15:8]								0x00
0xA6	ADC_C[7:0]								0x00
0xA7	ADC_C[15:8]								0x00
0xA8	ADC_IR[7:0]								0x00
0xA9	ADC_IR[15:8]								0x00

FIELD	DESCRIPTION
DEV_ID	Device ID (0x24)
REV_ID	Revision ID (0x0)
ADC_R	RED data
ADC_G	GREEN data
ADC_B	BLUE data
ADC_C	Clear data
ADC_IR	IR data

Information in this technical datasheet is believed to be correct and reliable. However, no responsibility is assumed for possible inaccuracies or omission. Specifications are subject change without notice.

OTRON ELECTRONIC TECHNOLOGY CO., LTD

TEL:+86-21-54971821

FAX:+86-21-54971823

EMAIL: otron.sensor@gmail.com

<http://www.e-otron.com>

7.Pin Configuration and Functions

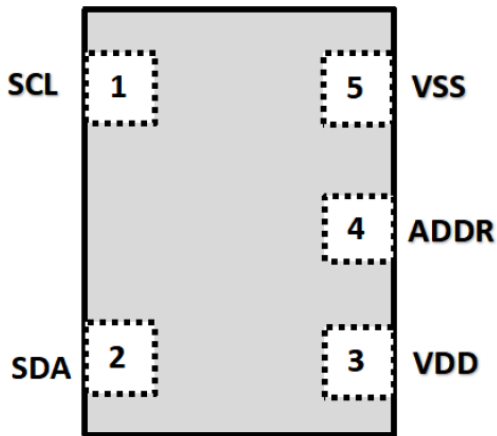

【Top View】

PIN	TYPE	DESCRIPTION
SCL	I	I2C serial clock input terminal
SDA	I/O	I2C serial data input/output terminal
VDD	P	Supply voltage
VSS	G	Supply Ground
ADDR	I	I2C device address input terminal (internal pull-up) - High or Floating : 7'b1000_011 - Low : 7'b1000_010

Information in this technical datasheet is believed to be correct and reliable. However, no responsibility is assumed for possible inaccuracies or omission. Specifications are subject change without notice.

OTRON ELECTRONIC TECHNOLOGY CO., LTD

TEL:+86-21-54971821

FAX:+86-21-54971823

EMAIL: otron.sensor@gmail.com

<http://www.e-otron.com>