

SILICON QUADRANT PHOTODIODE



Description

Φ3.57mm active area, low dark current quadrant photodiode
With P on N construction and 28μm gaps.

Features

- * Small gap (28μm)
- * Low dark current
- * High resolution
- * Operating temperature is from -40 to +80°C
- * Storage temperature is from -40 to +100°C
- * Soldering temperature is 260°C @Max.5 seconds at the position of 2mm from the PIN legs.

General Ratings

- * Type Silicon Photodiode
- * High linearity
- * Low dark current

Applications

- * Laser beam position sensor
- * Autocollimators
- * Optical tweezers
- * Ellipsometers

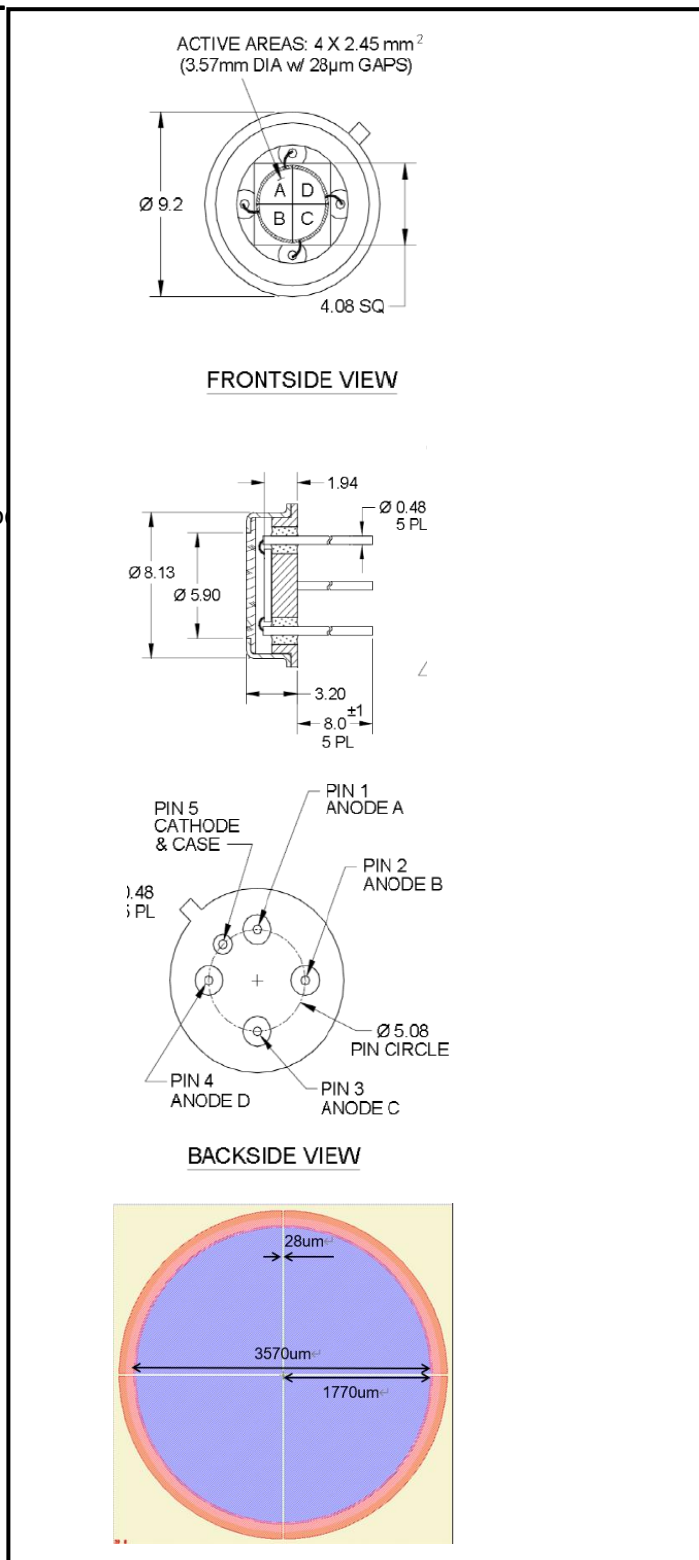

Information in this technical datasheet is believed to be correct and reliable. However, no responsibility is assumed for possible inaccuracies or omission.
Specifications are subject change without notice

OTRON ELECTRONIC TECHNOLOGY CO., LTD.

TEL:+86-21-54971821

FAX:+86-21-54971823

EMAIL: otron.sensor@gmail.com

[Http://www.e-otron.com](http://www.e-otron.com)



Absolute Maximum Ratings (Ta=25°C)

Parameter	Symbol	Condition	Min.	Typ.	Max.	Unit
Number of elements				4		
Active area (diamater)				Φ3.57		mm
Gap		Between elements		28		um
Spectral range			400		1100	μA
Photo sensitivity	S _R	940nm		0.60		A/W
		635nm		0.40		
Dark current	I _D	V _R =10mV		0.01		nA
		V _R =10V		0.26	2	
Rise time	t _R	V _R =10V; λ =850m;R _L =50Ω		20		ns
Tempcoeffi-cient of I _D	T _{CI_D}			0.18		times/°C
Operating voltage	V _{OP}		0		50	V
Reverse breakdown voltage	V _{(BR)R}	I _R =2μA Ev=0lx	20	50		V
Junction Capacitance	C _J	V _R =0V f=1MHz		161		pF
		V _R =10V f=1MHz		7		
		V _R =50V, R _L =50Ω		2		
CrossTalk Channel-to-Channel		400-850nm, Adjacent Channel		0.1	0.5	%
		850-1100nm, Adjacent Channels		1	5	
Uniformity of each Element	%		0.8		2	%
Shunt resistance	R _{sh}	V _R =5mV		250		MΩ
Rsh Temperature Coefficient	TC Rsh			0.18		%/°C
Angular Resp 50% Resp Pt	ε _{1/2}			±60		Degrees
Noise Equivalent Power	NEP	V _R =10V λ =940nm		1.8×10 ⁻¹⁴		W/Hz ^{1/2}
Specific Detectivity	D*	V _R =10V λ =940nm		5.6×10 ¹³		cm(Hz/W) ^{1/2}

Information in this technical datasheet is believed to be correct and reliable. However, no responsibility is assumed for possible inaccuracies or omission. Specifications are subject change without notice

OTRON ELECTRONIC TECHNOLOGY CO., LTD.

TEL:+86-21-54971821

FAX:+86-21-54971823

■ Dark current vs. reverse voltage

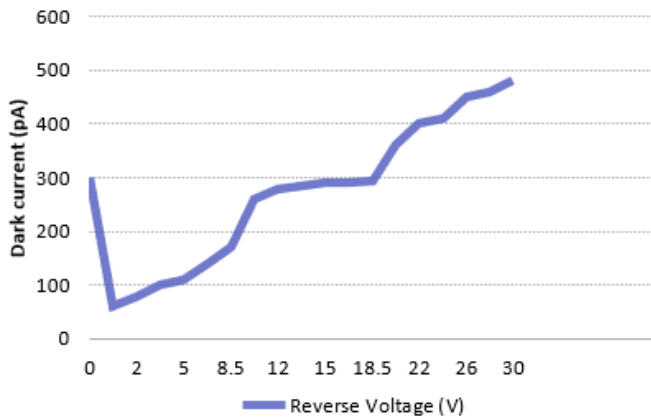

■ Spectral response

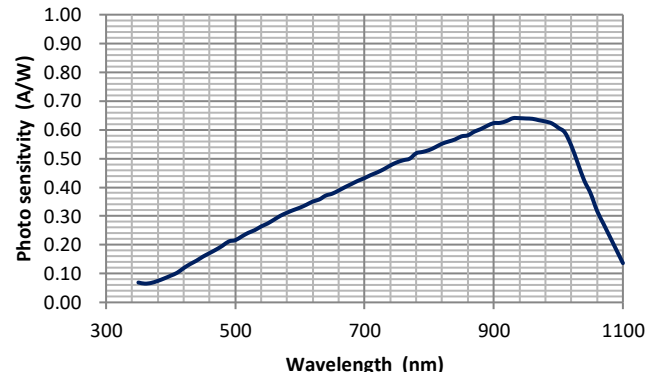

■ Relative Junction Capacitance

VS. Voltage

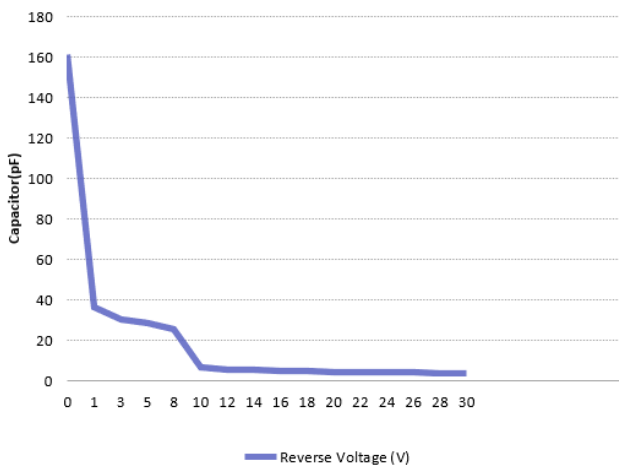

Information in this technical datasheet is believed to be correct and reliable. However, no responsibility is assumed for possible inaccuracies or omission. Specifications are subject change without notice

OTRON ELECTRONIC TECHNOLOGY CO., LTD.

TEL:+86-21-54971821

FAX:+86-21-54971823